

Doc. No.			
Version: 1.0	Audit No.: 0	In Total 7 Pages	1/7

## PRODUCT SPECIFICATION



Model	OHBF8190	Formulate	Tech.
Product name	Explosion-proof emergency LED lamp	Proofreading	
Brand: Ouhui		Review	
		Approve	
		Date	2019.6.25

Doc No.			
Version:1.0	Audit No.: 0	In Total 7 Pages	2/7

### 1. Picture of real products

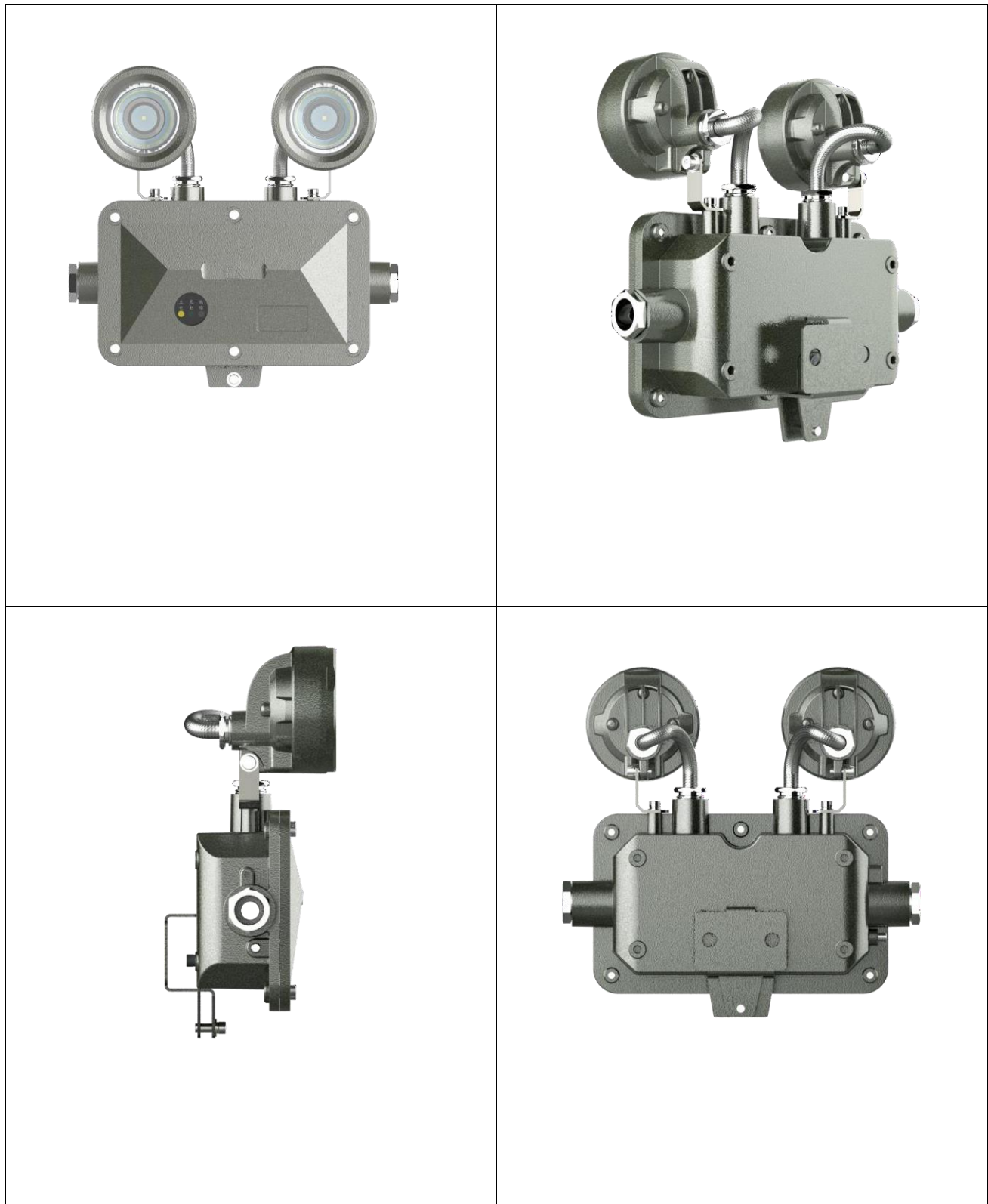

Doc No.			
Version:1.0	Audit No. : 0	In Total 7 Pages	3/7

## 2. Features

### 2.1. Application scenario

This product has good explosion-proof function, suitable for various inflammable and explosive places, mainly used in railway, electric power, metallurgy, petroleum, petrochemical, chemical, steel, aviation, ship and each Efficient lighting in factories, stations, large facilities, venues and other places.

### 2.2. Product Features

2.2.1. The lamp body is made of aluminium alloy by die casting. The surface of the lamp is sprayed with high voltage electrostatic. The exposed fasteners are stainless steel with high corrosion resistance, and the overall anti-corrosion performance is excellent.

2.2.2. Adopting high-intensity transparent shield, high-transparency, impact-resistant, unique anti-glare design, with unique optical reflector, it has the characteristics of high light efficiency and low light decay.

2.2.3. The explosion-proof structure designed in accordance with the national standard GB3836 document has reliable explosion-proof performance, long life, special constant current power supply, low power consumption and constant output power. It adopts high temperature and aging resistant silica gel sealing ring with high protection grade.

2.2.4. Adopt the international first-line brand light source chip, unidirectional luminescence, no side light, high light utilization rate, high light efficiency, high display finger, with open circuit, short circuit, overheat protection function, ensure the reliable and continuous operation of light source, wide voltage input, constant light flux output, instantaneous start-up.

2.2.5. Unique heat dissipation structure design, excellent and reliable heat dissipation performance, ensure the long life and reliable use of lamps.

2.2.6. Cable wiring, fast and convenient.be used as needed.

Doc No.			
Version:1.0	Audit No.: 0	In Total 7 Pages	4/7

### 3. Product Parameters

ITEM	symbol	Description	UNIT
Picture of real products OHBF8190			
Rated Voltage	VOLT	AC220	V
Emergency voltage	/	DC1.2	V
Power	P	2*3	W
Protection Level	IP	IP66	IP
Lighting Angle	$\theta$	38	°
LED Qty	/	2*1	PCS
Base specifications	/	CREE3030	
Anti-corrosion grade	/	WF2	
Explosion proof grade	/	Ex d IIB T6	
Light efficiency	$\eta$	120	Lm/W
Frequency	f	50/60	Hz
Power Factor	PF	>0.95	PF
Operating Temperature	TOPR	-30~50	°C
Storage Temperature	TOPR	-30~50	°C
Light Source	/	led	PCS
Correlate Color Temperature	Tc	6000	K
Color Rendering Index	CRI	≥70	RA
LED'S Operating Life	LIFE	100000	Hours
Start-up time	T	≤0.2	S
Executive standard	/	GB3836.1、 GB3836.2	
Weight	/	2.5	KG
Size	/	230x260x85	mm
Emergency Time	/	120	Min

Doc No.			
Version:1.0	Audit No.: 0	In Total 7 Pages	5/7

## 4. Dimensions

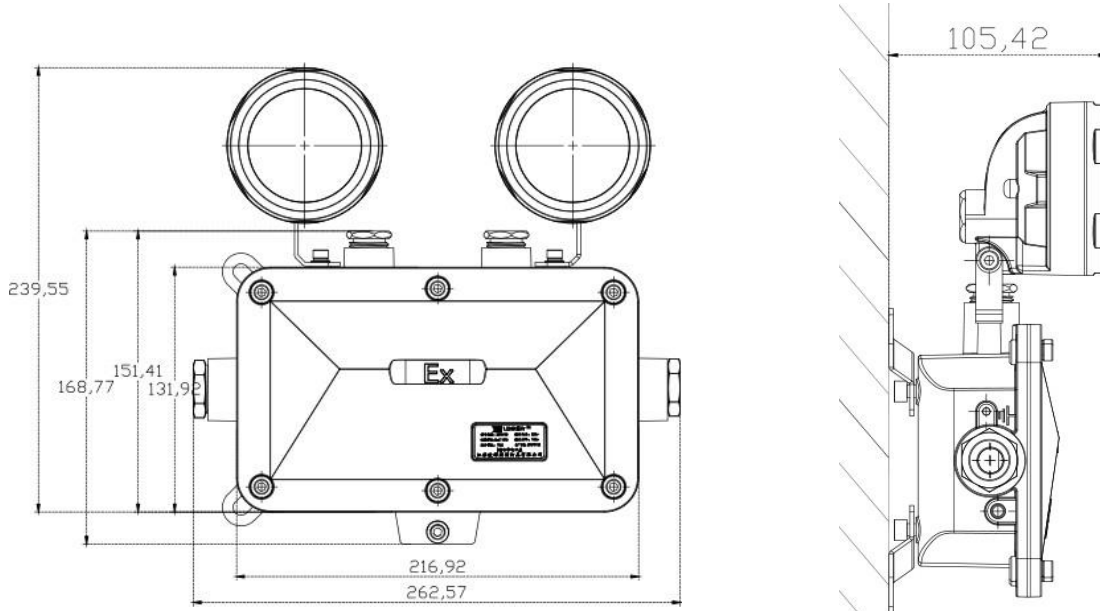

## 5. Install

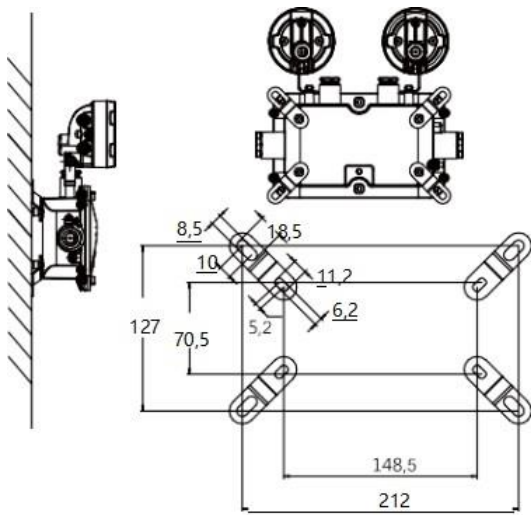

A. 常规挂壁式

- ①根据现场环境需求以及上图定位尺寸确定打孔位置。
- ②调整四角安装支架，紧固螺丝，确保安装牢固可靠,安装完成。

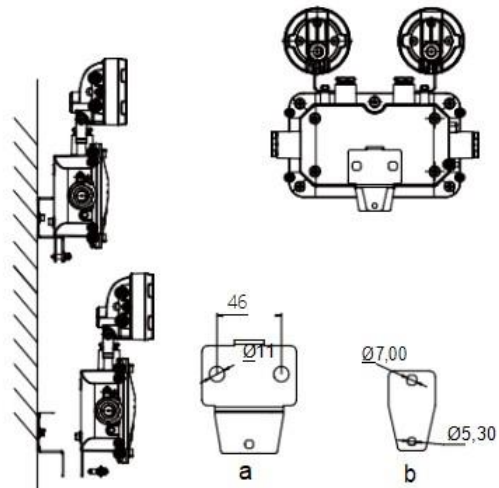

B. 便捷挂壁式

- ①根据现场环境需求以及上图定位尺寸，把安装支架a固定在墙面，确保安装牢固，把支架b安装在灯具上。
- ②用支架b下端插入支架a的安装槽内并用螺丝固定，紧固螺丝，安装完成。

Name	Description	Quantity	Name	Parameter
Outer box	46.8*31.8*28cm	1	N.W.	2.5 kg
Inner box	29.8*11.2*25.5cm	1	G.W.	Kg
Packaging method		1 hold 4		

## 6. Caution

### 1、 Schematic diagram

1. Before installation, it is necessary to check whether the actual operating conditions are in conformity with the parameters listed on the lamp nameplate.
2. Before installation, please test the lighting according to the parameters of the lamp nameplate to ensure that there is no quality problem before installation.
3. Before installation, it is necessary to determine the installation location and mode of the lamps according to the installation mode provided by the product, in combination with the on-site use environment and lighting requirements, so as to ensure that the installation is firm and reliable.
4. Connect the prepared cables with the input cables of lamps and lanterns according to the corresponding fire (brown), zero (blue) and ground (yellow-green) wires, so as to ensure that the connection is firm, and make good insulation and waterproof measures at the connection.
5. The input end of the cable can be connected to the power supply of the corresponding voltage to illuminate.

### 2、 Using The Matters Needing Attention

1. This product is an explosion-proof product and can be used in explosion-proof places.
2. When transporting, the lamp should be installed in the carton equipped with foam shock absorption.
3. When using, the surface of the lamp has a certain temperature rise, which is a normal phenomenon.
4. The power supply voltage can work normally in the rated voltage. If the power supply voltage is too high, the lamp will be damaged; if the voltage is too low, the lamp will not start normally.
5. The luminaire must be reliably grounded.

### 3、 Quality Assurance

The company has passed ISO9001:2008 international quality system audit certification, this product strictly implements ISO9001 international quality management system standard production, to ensure that the product quality fully meets national standards and design requirements.